



FORGED SUPERLITE CALIPER

Caliper Highlights:

The Superlite caliper series has set the standard for many years in short track, late model, modified and open wheel competition. It has also enjoyed prominence in a variety of road-race, off-road, rally and sport driving applications. The **Forged Billet Superlite (FSL)** is the newest innovation to this series from Wilwood. New and adaptive technologies have been applied providing substantial improvements in strength, fluid volume displacement, and overall performance.



The most noteworthy feature of this new caliper design is the forging. Each body is stress-flow forged from premium grade aluminum alloy billets. Stress-flow forging re-aligns the metal's internal grain structure to flow within the contour of the caliper body. This process eliminates the stresses and interruptions to the internal grain structure that occur when machining a straight block billet. Simply stated, there is no better way to build a stronger aluminum caliper body.

The **FSL** body design is a highly efficient product of computer generated solid modeling and stress analysis technology. Each caliper features closed end bridges with a radial transition to the piston body housings. The elimination of machined steps and sharp shoulders in this critical area provides a measurable increase in overall body strength and resistance to deflection under load. Center bridge bolts replace cotter pins to provide additional support and allow quick access with positive brake pad retention. Clamping force, structural deflection, and volume displacement tests have proven the superior strength and efficiency of the **FSL**. On-track testing has proven driver satisfaction. The bottom line is better stopping power with less pedal travel.

The superior strength of this innovative new caliper is combined with proven performance features from other Wilwood designs. Each caliper is equipped with Wilwood's replaceable SRS stainless steel bridge plates. SRS plates eliminate the bridge wear caused by pad gouging and extend the service life of the caliper body. The spring-loading action of the SRS plates also eliminates pad rattle and dampens the vibration harmonics that contribute to squeal under braking. Other standard Wilwood features include high-temperature, square faced o-ring seals for positive sealing, controlled piston retraction, and long service life in high heat conditions. Stainless steel pistons are used to resist corrosion and retard heat transfer from the pads. Fluid tubes are vibration dampened to resist stress fractures and reduce damage caused by track debris. Two-piece bleed screw assemblies provide long, reliable service life and are easily replaced if necessary.

Forged Billet Superlite calipers are a direct replacement for all Wilwood Superlite and similar competitive brand calipers with 3.50" centered mounting tabs. Calipers are available in the popular 1.75" and 1.38" piston sizes for .81", 1.10" and 1.25" rotor widths. **FSL** calipers use the same 7420 type bridge bolt brake pad used in all Superlite 6 piston calipers. The full range of PolyMatrix pad compounds is available to match brake response and heat range to any application.

ORDERING INFORMATION:

BORE SIZE		DISC WIDTH		PART NUMBER
1.75"	44,5 mm	1.25"	31,8 mm	120-7429-R/L
1.75"	44,5 mm	1.10"	27,9 mm	120-7476-R/L
1.75"	44,5 mm	.81"	20,6 mm	120-7430-R/L
1.75"	44,5 mm	.81"	20,6 mm	120-7430-SI
1.38"	35,0 mm	1.25"	31,8 mm	120-7431-R/L
1.38"	35,0 mm	1.10"	27,9 mm	120-7477-R/L
1.38"	35,0 mm	.81"	20,6 mm	120-7432-R/L
1.25"	31,8 mm	1.25"	31,8 mm	120-7792-R/L
1.25"	31,8 mm	.81"	20,6 mm	120-7794-R/L
1.12"	28,4 mm	1.25"	31,8 mm	120-8282-R/L
1.12"	28,4 mm	.81"	20,6 mm	120-8283-R/L

FORGED BILLET SUPERLITE CALIPER, MOUNTING DIMENSIONS:

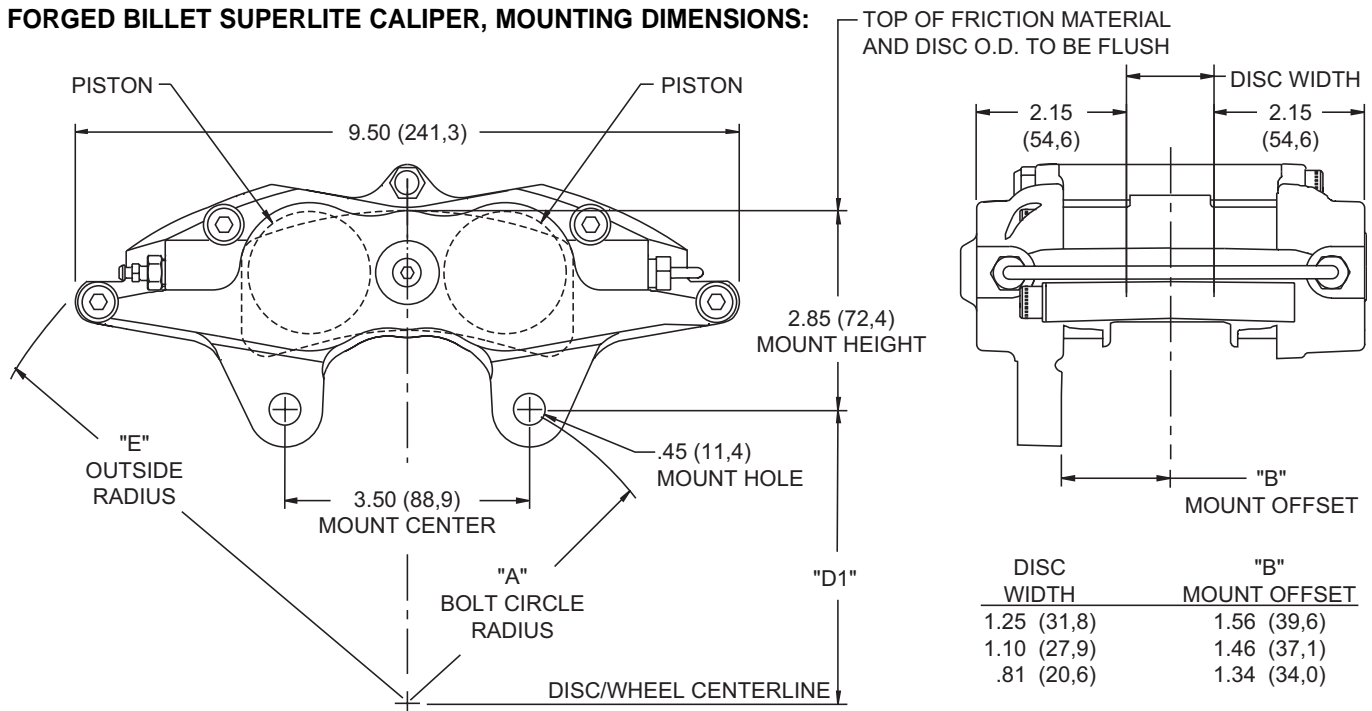

DISC WIDTH	"B" MOUNT OFFSET
1.25 (31,8)	1.56 (39,6)
1.10 (27,9)	1.46 (37,1)
.81 (20,6)	1.34 (34,0)

DIMENSION "D1" = (DISC DIAMETER/2) - 2.85 (72,4)

NOTE: RIGHT HAND CALIPER SHOWN. LEFT HAND CALIPER HAS BLEED SCREW AND CROSSOVER TUBE REVERSED.

INLET FITTING: 1/8-27 NPT

DISC DIAMETER	"A" BOLT CIRCLE RADIUS	"E" OUTSIDE RADIUS
11.75 (298,5)	3.50 (88,9)	6.69 (169,9)
12.19 (309,6)	3.69 (93,7)	6.85 (174,0)
12.72 (323,1)	3.92 (99,6)	7.05 (179,1)
12.88 (327,2)	4.00 (101,6)	7.12 (180,8)
13.00 (330,2)	4.05 (102,9)	7.18 (182,4)

FORGED BILLET SUPERLITE CALIPER, TYPE 7420 PAD DIMENSIONS AND ORDERING INFORMATION:

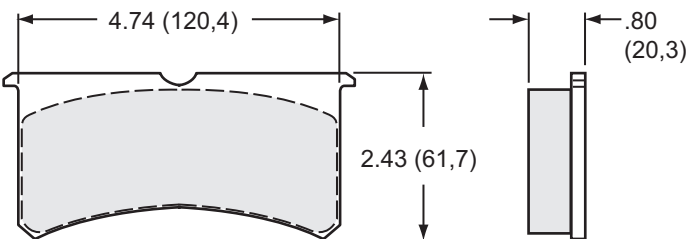

AXLE SET PART NO.	PAD TYPE/COMPOUND
15A - 5938K	7420 A PolyMatrix
15B - 5939K	7420 B PolyMatrix
15C - 6853K	7420 C PolyMatrix
15E - 6084K	7420 E PolyMatrix
15H - 8114K	7420 H PolyMatrix
15J - 6443K	7420 J PolyMatrix
15Q - 6829K	7420 Q PolyMatrix
15T - 5916K	7420 T PolyMatrix

ORDERING INFORMATION, USER SERVICEABLE COMPONENTS:

CALIPER PART NO.	PISTON	SQ RING KIT (4 PK)	BLEED SCREW KIT (4 PK)	CROSSOVER TUBE KIT (4 PK)	SELF BLEED TUBE (EA)	BRIDGE BOLT KIT	BRIDGE WEAR PLATE-R/L (EA)
120-7429	200-3062 (1.75")	130-2655	220-6069	190-5975	190-8310	230-7541	300-5922/23
120-7430	200-3062 (1.75")	130-2655	220-6069	190-5973	—	230-7539	300-5922/23
120-7431	200-3176 (1.38")	130-2658	220-6069	190-5975	190-8310	230-7541	300-5922/23
120-7432	200-3176 (1.38")	130-2658	220-6069	190-5973	—	230-7539	300-5922/23
120-7476	200-3062 (1.75")	130-2655	220-6069	190-5974	—	230-7540	300-5922/23
120-7477	200-3176 (1.38")	130-2658	220-6069	190-5974	—	230-7540	300-5922/23
120-7792	200-4655 (1.25")	130-2479	220-6069	190-5975	190-8310	230-7541	300-5922/23
120-7794	200-4655 (1.25")	130-2479	220-6069	190-5973	—	230-7539	300-5922/23
120-8282	200-6307 (1.12")	130-2579	220-6069	190-5975	190-8310	230-7541	300-5922/23
120-8283	200-6307 (1.12")	130-2579	220-6069	190-5973	—	230-7539	300-5922/23